

Well-being for your feet

Drying and Disinfection System

for boots and shoes – model HYGIfeet M 20 – D 60

- Safe disinfection by ozone**
 No chemical consumption
 Killing of germs prevents the spread of diseases
- Modular construction**
 The combination of boot and shoe drying with disinfection is possible
 Machine suitable for single or double sided feed
 Capacity range 5 - 60 pairs
 Mobile
- Short drying time ensured by hot air operation**
 Warm, dry boots increase the employee's well-being
 Valve heads enable controlled hot air feed
- Machine made completely from Stainless Steel**
 Micro processor control
 Weekly, daily and hourly programming - via a digital display
 Electrical supply: 230 V, 50 Hz
 Low current consumption: 1.3 kW
 Machine supplied ready for use



HYGIfeet D 60

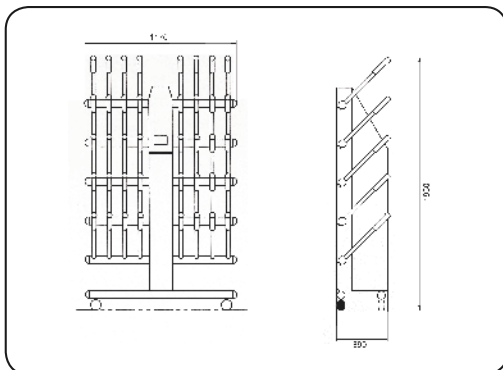

Part No. SE.20.120

HYGIfeet M 20

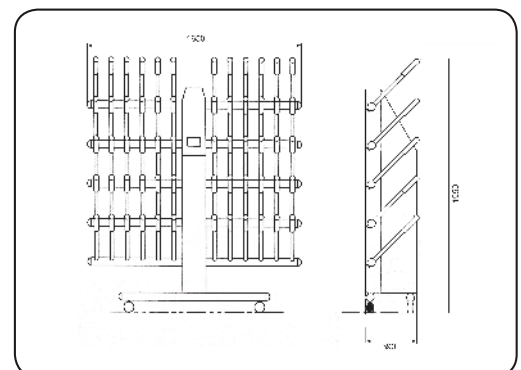

Part No. SE.20.130

HYGIfeet M 30

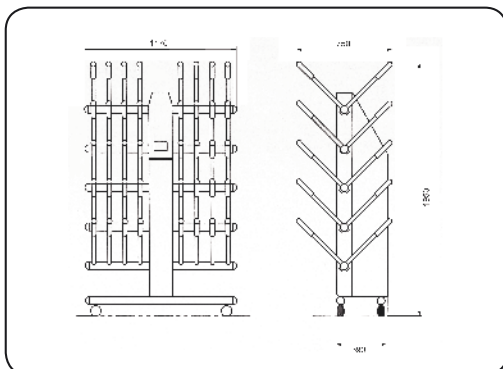

Part No. SE.20.140

HYGIfeet D 40

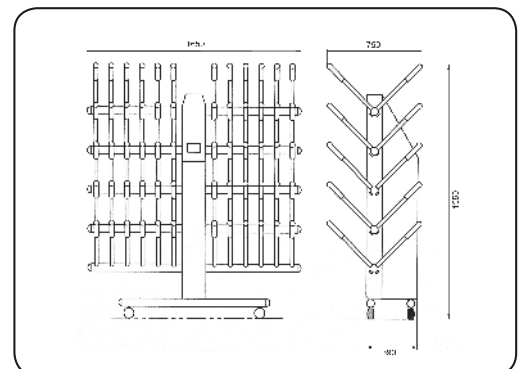

Part No. SE.20.160

HYGIfeet D 60

Managing hygiene requires reliable partners

PHT - PARTNER für HYGIENE und TECHNOLOGIE GmbH
 Förchenholzstr. 19 Tel. +49 (0)80 41 / 7 99 24 - 0
 83646 Bad Tölz Fax +49 (0)80 41 / 7 99 24 - 25
 Deutschland Email: info@pht-gmbh.de
 Internet: www.pht-gmbh.de

PHT - SA Partner for Hygiene & Technology
 58 Henri Road Tel. +27 83 400 6264
 Eldoraigne, Centurion Fax +27 86 628 9800
 South Africa Email: info@pht-sa.co.za
 Internet: www.pht-sa.co.za

Machine combination: boots and shoes, can be arranged individually

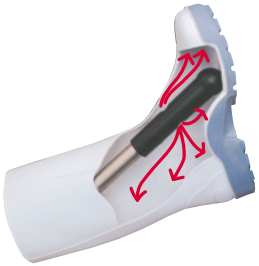

The valve heads only inject the hot air/ozone mixture, if the boots are in position. Good valve head design ensures optimum air circulation - this results in short drying times.



Optimum hygiene for light shoes is guaranteed through special supports for shoes and control of the hot air - ozone mixture.

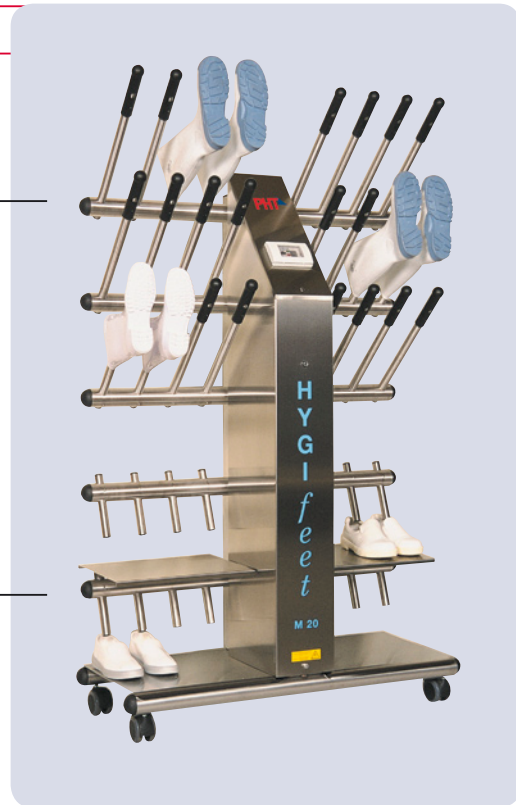

HYGif feet - M 5 - M 10 - M15

- **Compact design**

Electrical Supply: 230 V, 50 Hz
 Low current consumption: 1.1 kW
 Time control with time switch
 Capacity range 5 -15 pairs
 With pedestal or with rollers

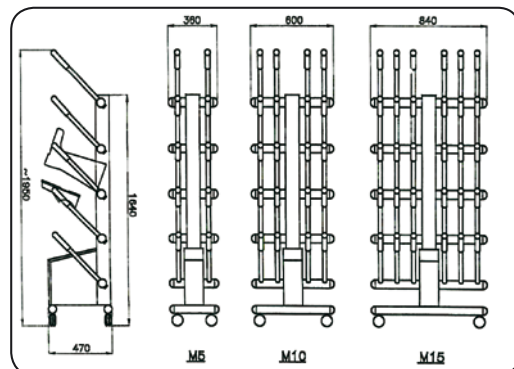

Part No. SE.20.105 SE.20.110 SE.20.115

Managing hygiene requires reliable partners